

SIL – Safety Manual SM.0002 Rev 02

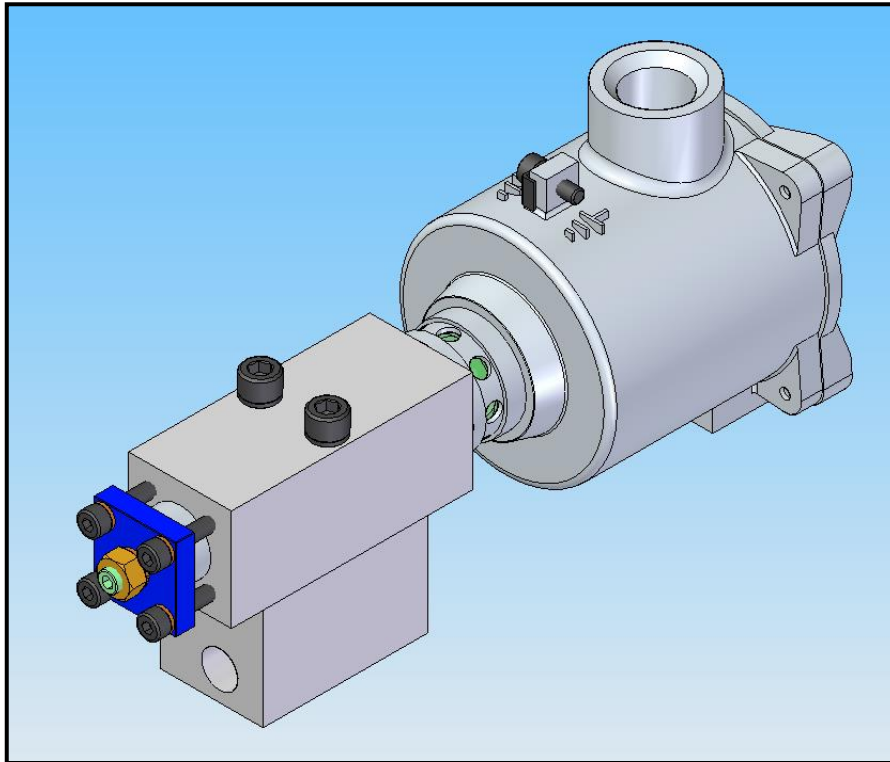

Solenoid Valves For Gas Service FP02G & FP05G

Compiled By : G. Elliott, Date: 31/10/2017
Reviewed By : Peter Kyrycz Date: 31/10/2017



Contents

Terminology Definitions	3
Acronyms & Abbreviations	4
1. Introduction	5
1.1 Scope	5
1.2 Relevant Standards	5
1.3 Other related documents and papers	5
2. Device Description	5
2.1 Safety Function	5
2.2 Environmental Limits	5
2.3 Application Limits	5
2.4 Design Verification	5
2.5 Sil Capability	6
2.5.1 Systematic Integrity	6
2.5.2 Random Integrity	6
3. Installation & Commissioning.....	7
3.1 Installation	8
3.2 Proof testing	8
3.3 Repair & Replacement	9
3.4 Useful Life	9
3.5 Reporting Concerns to Bifold	9

Terminology Definitions:

Description	Explanation
<i>Safety:</i>	Freedom from unacceptable risk of harm.
<i>Functional Safety:</i>	The ability of a system to carry out the actions necessary to achieve or to maintain a defined safe state for the equipment / machinery / plant / apparatus under control of the system.
<i>Basic Safety:</i>	The equipment must be designed and manufactured such that it protects against risk of damage to persons by electrical shock and other hazards and against resulting fire and explosion. The protection must be effective under all conditions of the nominal operation and under single fault condition.
<i>Safety Assessment:</i>	The investigation to arrive at a judgment - based on evidence - of the safety achieved by safety-related systems.
<i>Fail-Safe State:</i>	State where solenoid valve is de-energized and spring is extended.
<i>Safe Failure</i>	Failure that causes the valve to go to the defined fail-safe state without a demand from the process.
<i>Dangerous Failure</i>	Failure that does not respond to a demand from the process (i.e. being unable to go to the defined fail-safe state).
<i>Dangerous Undetected Failure</i>	Failure that is dangerous and that is not being diagnosed by automatic stroke testing.
<i>Dangerous Detected:</i>	Failure that is dangerous but is detected by automatic stroke testing.
<i>Fail Annunciation Undetected</i>	Failure that does not cause a false trip or prevent the safety function but does cause loss of an automatic diagnostic and is not detected by another diagnostic.
<i>Fail Annunciation Detected:</i>	Failure that does not cause a false trip or prevent the safety function but does cause loss of an automatic diagnostic or false diagnostic indication.
<i>Fail No Effect:</i>	Failure of a component that is part of the safety function but that has no effect on the safety function.
<i>Low demand mode:</i>	Mode, where the frequency of demands for operation made on a safety-related system is no greater than twice the proof test frequency.

Acronyms / Abbreviations

Acronym / Abbreviation	Description	Explanation
CCF	Common Cause Failure	A common cause failure is one in which a single failure or condition affects the operation of multiple devices that would otherwise be considered independent. Common cause failures can result in the SIS failing to function when there is a process demand.
FITS	Failures in Time	The number of failures that can be expected in one billion (10^9) device-hours of operation.
FMEDA	Failure Modes, Effects & Diagnostics Analysis	A method of assessing a hardware device in order to predict failure rates and hence determine the applicable SFF.
HFT	Hardware Fault Tolerance	Ability of a functional device to continue to perform a required function when faults or errors are prevailing.
LOPA	Layers of Protection Analysis	LOPA is a methodology for hazard evaluation and risk assessment.
MTBF	Mean Time Between Failures	Mean time Between Failures. ($1/\lambda$).
MTTR	Mean Time To Repair	Mean time between the occurrence of an error in a unit or system and its repair.
OIM	Operation & Installation Manual	Information on correct installation, maintenance and testing.
PFD	Probability of Failure on Demand	Probability of failures for a safety function on demand
PFD _{avg}	Average Probability of Failure on Demand	Average Probability of failures for a safety function on demand
PTI	Proof Test Interval	The time between diagnostic testing or Partial Stroke Testing.
SIL	Safety Integrity Level	The international standard IEC61508 defines four discrete Safety Integrity Levels (SIL 1 to SIL 4). Each level corresponds to a range of probability for the failure of a safety function. The higher the SIL level the lower the probability that they will not perform the required safety function
SFF	Safe Failure Fraction	The proportion of non-hazardous failures.
λ	Failure Rate	Failure Rate – the ratio of the total number of failures in a given time period
λ_D	Dangerous Failure Rate	Failure Rate of Dangerous failures (per hour).
λ_{DD}	Dangerous Detected Failure rate	Failure Rate of Dangerous failures detected by diagnostic testing (per hour).
λ_{DU}	Dangerous Undetected Failure Rate	Failure Rate of Dangerous failures Undetected by diagnostic testing (per hour).
λ_s	Safe Failure Rate	Failure Rate of Safe failures (per hour).

1. Introduction

1.1 Purpose & Scope

This manual provides the results of a functional safety assessment of Solenoid Valve For Gas Service, by Exida Consulting in accordance with IEC61508: ed2: 2010.

The results of this provides the safety instrumentation engineer with the required failure data as per IEC61508 / IEC 61511, and confidence that sufficient attention has been given to systematic failures during the development of the device.

1.2 Relevant Standards

IEC 61508 (Parts 1 – 7) Ed2: 2010 - Functional Safety of Electrical /Electronic/Programmable Electronic Safety-Related Systems.

1.3 Other Related documents and papers

Exida FMEDA Report : BIF-06-01-17 R002 V5R1 FMEDA

Device	Document ID	Document Type
FP02G & FP05G	BFDD15/0	Data Sheet
FP02G & FP05G	OPB0179	Operating & Installation Manual
FP02G & FP05G	Catalogue 29 – FP02G & FP05G – Gas Service	Product Catalogue

2. Device Description

The FP02G/FP05G is a 3 Port, 2 position, solenoid valve for use on Gas Service

2.1 Safety Function

When de-energised (signal removed), the valve moves to its fail-safe position, where the return spring is extended. The valve will operate to close off the flow path through the valve body, and divert it to tank / exhaust.

The FP02G/FP05G Solenoid Valves For Gas Service are designed to be part of a final element subsystem as defined by IEC61508 and the achieved SIL level of the designed function must be verified by the system designer.

2.2 Environmental Limits

The designer of a SIF must verify that the product is rated for use within the expected environmental limits.

For SIL rated valves the minimum operating temperature is – 20 °C.

Refer to Bifold Product Catalogue for more information.

2.3 Application Limits

The materials of construction are specified in the various Bifold Catalogues and Data Sheets. Maximum Operating Pressure is up to 210 Bar.

2.4 Design Verification

A Failure Mode, Effects, and Diagnostics Analysis (FMEDA) report has been carried out independently by Exida.com and is available from Bifold on request. The achieved Safety Integrity Level (SIL) of an entire Safety Instrumented Function (SIF) design must be verified by the designer via a calculation of PFD_{average} considering architecture, proof test interval, proof test effectiveness, any automatic diagnostics, average repair time and the specific failure rates of all products included in the SIF. Each subsystem must be checked to assure compliance with minimum hardware fault tolerance (HFT) requirements.

When using Gas Service Solenoid Valves in a redundant configuration, a common cause factor of 10% should be included in safety integrity calculations.

The failure rate data listed the FMEDA report is only valid for the useful life time of a valve.

The failure rates will increase sometime after this time period.

Reliability calculations based on the data listed in the FMEDA report for mission times beyond the lifetime may yield results that are too optimistic, i.e. the calculated Safety Integrity Level will not be achieved.

2.5 SIL Capability

2.5.1 Systematic Integrity

The product has met manufacturers design process requirements of **Safety Integrity Level (SIL) 3**.



These are intended to achieve sufficient integrity against systematic errors of design by the manufacturer.

A Safety Instrumented Function (SIF) designed with this product must not be used at a SIL level higher than the statement without “prior use” justification by end user or diverse technology redundancy in the design.

Please refer to the Exida FMEDA report for specific Lambda Values.

2.5.2 Random Integrity

The FP02G & FP05G Solenoid Valves are classified as devices that are part of a TYPE A element according to IEC 61508, having a hardware fault tolerance (HFT) of 0. When the final element assembly consists of many components (Solenoid Valve, quick exhaust valve, etc.), the SIL must be verified for the entire assembly using failure rates from all components. This analysis must account for any hardware fault tolerance and architecture constraints. According to IEC 61508 the architectural constraints of an element must be determined. This can be done by following the Route 1H approach according to 7.4.4.2 of IEC 61508 or the Route 2H approach according to 7.4.4.3 of IEC 61508.

The Route 1H approach involves calculating the Safe Failure Fraction for the entire element. The Route 2H approach involves assessment of the reliability data for the entire element according to 7.4.4.3.3 of IEC 61508.

The FP02G & FP05G Solenoid Valves meet the exida criteria for Route 2H; therefore, the FP02G & FP05G Solenoid Valves can be classified as 2H devices. When 2H data is used for all of the devices in an element, the element meets the hardware architectural constraints up to SIL 2 at HFT=0 (or SIL 3 @ HFT=1).

If Route 2H is not applicable for the entire final element, the architectural constraints will need to be evaluated per Route 1H. If the SFF of the element is >90%, and the PFDavg < 10⁻³, the design can meet SIL 3 @ HFT=0.

3.0 Installation and Commissioning

3.1 Installation

The device must be installed per standard practices outlined in the Installation Manual. The environment must be checked to ensure that environmental conditions do not exceed the ratings.

The device must be accessible for physical inspection.

3.2 Proof Testing

The Device should be subjected to a full test at least once every 12 months (or more frequently based on the desired PFDavg calculations – Ref Section 2.4). This would normally be conducted as parts of a proof test or partial stroke test for the actuator under control. Partial stroke testing of the Safety Instrumented Function (SIF) must provide a full test of the device.

According to section 7.4.3.2.2 f) of IEC61508-2, proof tests shall be undertaken to reveal dangerous faults which are undetected by diagnostic tests. This means that it is necessary specify how dangerous undetected faults which have been noted during the FMEDA can be detected during proof testing.

3.2.1 Suggested Proof Test

The suggested proof test consists of a full stroke of the solenoid valve, as described in the table below. This test will detect 94% of the possible DU failures of the FP02G/FP05G Valves, when PVST is not being performed.

Step	Action
1	Bypass the safety function and take appropriate action to avoid a false trip
2	Send a signal to the solenoid to perform a full stroke and verify that this is achieved.
3	Inspect the solenoid for any visible damage or contamination.
4	Remove the bypass otherwise restore normal operation.

3.3 Repair and Replacement

Repair procedures must be implemented as per the Operation, Installation and Maintenance Manual for the device.

The SIL rating of the valve will be voided if the repair is not performed with Genuine Bifold parts and serviced by a competent person.

3.4 Useful Lifetime for the Device.

The Useful Lifetime of the device is considered to be 10 years or 10,000 cycles - whichever occurs first. (However, the lifetime of the device can be extended to 20 years or 20,000 cycles if properly maintained in accordance with the Bifold Operation, Installation & Maintenance Manual)

3.5 Reporting Concerns to Bifold

All faults to be reported to Bifold for recording purposes, by contacting the Quality Department at the supplying facility listed at the bottom of the page All defective devices must be returned Bifold for investigation and rectification by the Manufacturer. A Valve Return and Service Report form (VRSR) – available upon request, form the supplying facility - (Contact details at the foot of this page) must be completed and returned with the device.